

EM-S

Segment sleeve mandrels

Clamping diameter \varnothing 18 - 105 mm

- For ID clamping
- Rigid design

EM-S

Segment sleeve mandrel
power operated

Segment sleeve mandrel Ø 18 - 105 mm

- Size 1 - 4
- Large expansibility

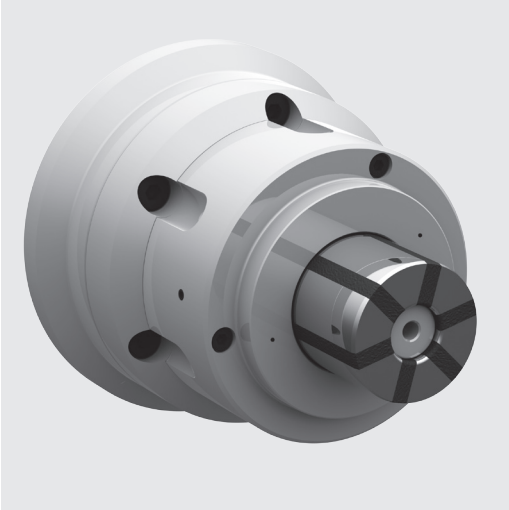

Application/ customer benefits

- Ideal for volume production and hard turning / grinding with wear resistant, case hardened and vulcanised clamping sleeves
- Highest accuracy and high torque transmission by means of fixed mandrel body
- Axial pull down by the axial clamping movement of the clamping sleeve = best face run out
- Clamping sleeve quick change for short setup times
- Preparation for air sensing

Technical details

- Large expansibility 0.8-1.2 mm depending on the size (The clamping sleeves have a max. radial expansibility in diameter of ± 0.4 mm or ± 0.6 mm from the nominal diameter.)
- Power operated
- Rigid design with flange mounting
- Tapped holes in the face for axial stops

Standard equipment

Base mandrel with mounting bolts

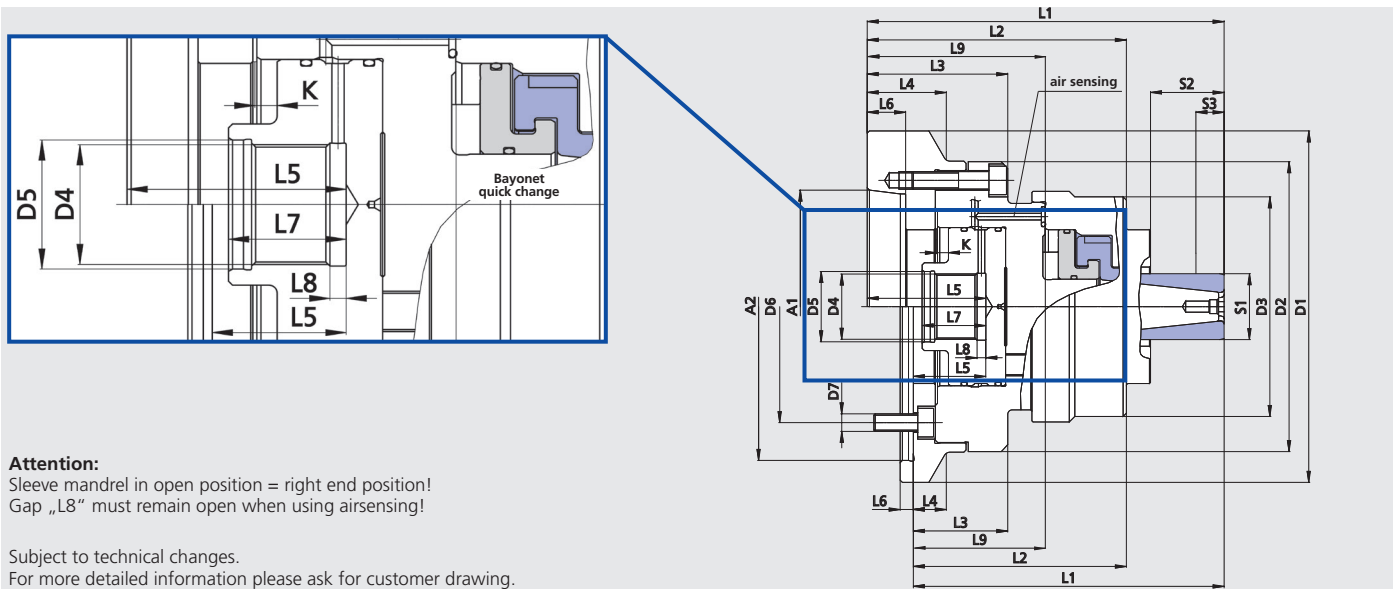

Attention:
Sleeve mandrel in open position = right end position!
Gap „L8“ must remain open when using airsensing!

Subject to technical changes.
For more detailed information please ask for customer drawing.

SMW-AUTOBLOK Type	EM-S-1			EM-S-2			EM-S-3					EM-S-4				
Mounting	A5	A6	Z140	A5	A6	Z140	A5	A6	A08	Z140	Z170	A5	A6	A8	Z140	Z170
Id. No.	202734	202735	205082	202737	202738	205085	202740	202741	203132	205086	205134	203384	203385	203427	205088	205089
Short taper mounting DIN 55026	A1	A5	A6	-	A5	A6	-	A5	A6	A8	-	-	A5	A6	A8	-
Center mounting	A2 H5	-	-	140	-	-	140	-	-	-	140	170	-	-	-	140
	D1	132	160	150	132	160	150	132	160	202	150	180	157	157	202	157
	D2	132	132	132	132	132	132	132	132	132	132	132	157	157	157	157
	D3	82	82	82	100	100	100	114	114	114	114	114	143	143	143	143
	D4	M30x1.5	M30x1.5	M30x1.5	M30x1.5	M30x1.5	M30x1.5	M30x1.5	M30x1.5	M30x1.5	M30x1.5	M30x1.5	M30x1.5	M30x1.5	M30x1.5	M30x1.5
	D5 H7	32	32	32	32	32	32	32	32	32	32	32	32	32	32	32
	D6	104.8	133.4	104.8	104.8	133.4	104.8	104.8	133.4	171.4	104.8	133.4	104.8	133.4	171.4	104.8
	D7	4 x M10	4 x M12	3 x M10	4 x M10	4 x M12	3 x M10	4 x M10	4 x M12	4 x M16	3 x M10	6 x M12	4 x M10	4 x M12	4 x M16	3 x M10
	L1	138.5	138.5	123.5	162.5	162.5	147.5	177.5	177.5	179.5	162.5	162.5	193	191	195	193
	L2	113.5	113.5	98.5	118	118	103	123	123	126	108	108	132.5	130.5	134.5	132.5
	L3	61	61	46	64	64	49	75	75	77	60	60	80	78	82	80
	L4	-	36	15	-	36	15	-	36	47	15	30	-	-	47	-
	L5	53	53	38	54	54	39	50	50	52	35	35	54	52	56	54
	L6	16.5	17.5	6	16.5	17.5	6	16.5	17.5	20	6	6	19	17.5	20	5
	L7	30	30	30	29	29	29	25	25	25	25	25	29	29	29	29
Gap	L8	4	4	4	4	4	4	4	4	4	4	4	5	5	5	5
	L9	79	79	64	81	81	66	75	75	77	60	60	80	78	82	80

Technical data

	S1	18-23	23-35	18-23	23-35	18-23	23-35	30-55	30-55	30-55	45-80	45-80	45-80	45-80	45-80	70-105	70-105	70-105	70-105	70-105
Clamping range	S1	18-23	23-35	18-23	23-35	18-23	23-35	30-55	30-55	30-55	45-80	45-80	45-80	45-80	45-80	70-105	70-105	70-105	70-105	70-105
max. clamping length	S2	17.5	23	17.5	23	17.5	23	41.5	41.5	41.5	51.5	51.5	51.5	51.5	51.5	57.5	57.5	57.5	57.5	57.5
min. clamping length	S3	7	7	7	7	7	7	8	8	8	8	8	8	8	8	8	8	8	8	8
Axial stroke	K	4	4	4	4	4	4	6	6	6	6	6	6	6	6	6	6	6	6	6
Expansibility in dia.		0.8	0.8	0.8	0.8	0.8	0.8	1.2	1.2	1.2	1.2	1.2	1.2	1.2	1.2	1.2	1.2	1.2	1.2	1.2
max. actuating force	kN	15	15	15	15	15	15	20	20	20	25	25	25	25	25	29	29	29	29	29
max. speed	r.p.m.	5000	5000	5000	5000	5000	5000	5000	5000	5000	5000	5000	5000	5000	5000	5000	5000	5000	5000	5000
max. transmittable torque	Nm	57	57	57	57	57	57	102	102	102	180	180	180	180	180	395-595	395-595	395-595	395-595	395-595
rec. actuating cylinders		SIN-S 70					SIN-S 85					SIN-S 85								

Segment sleeve mandrel Ø 18 - 105 mm

EM-S

Segment sleeve mandrel
power operated

- Size 1 - 4
- Large expansibility

Technical design

1. Basic body EM-S with spindle adapter
2. Segment sleeve mandrel (vulcanized + case hardened) with bayonet quick change.
Clamping sleeves in size EM-S-1 with three segments, clamping sleeves from size EM-S-2 on with six segments for better gripping force distribution.
3. Workstop

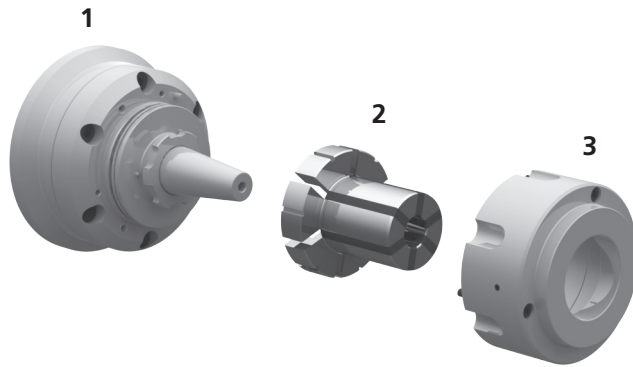

Overview clamping ranges

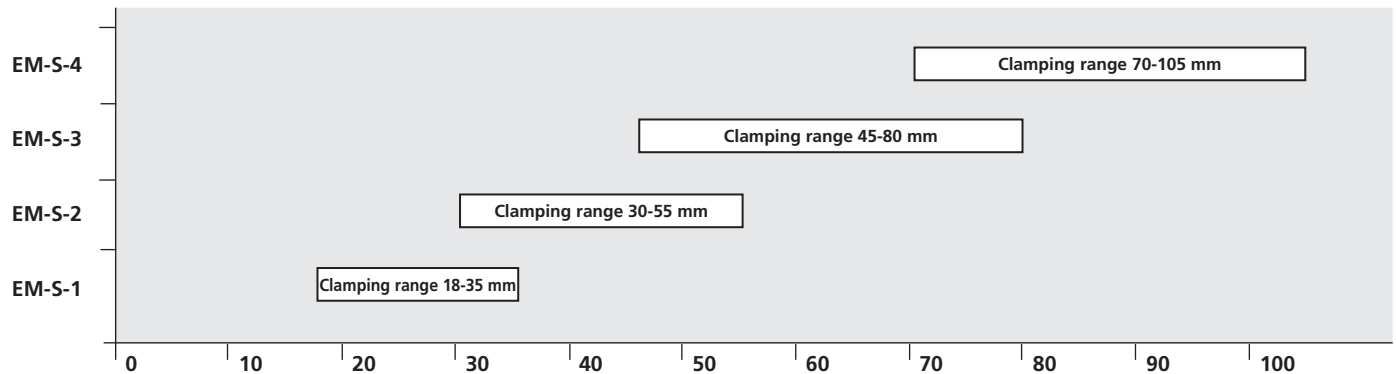

Clamping sleeves

EM-S-1*

Ø	18	19	20	21	22	23	24	25	26	27	28	29	30
Id. No.	204716	203026	203027	203028	203029	203030	203031	203032	203033	203034	203035	203036	203037
Ø	31	32	33	34	35								
Id. No.	203038	203039	203040	203041	203042								

EM-S-2**

Ø	30	31	32	33	34	35	36	37	38	39	40	41	42
Id. No.	203043	203044	203045	203046	203047	203048	203049	203050	203051	203052	203053	203054	203055
Ø	43	44	45	46	47	48	49	50	51	52	53	54	55
Id. No.	203056	203057	203058	203059	203060	203061	203062	203063	203064	203065	203066	203067	203068

EM-S-3**

Ø	45	46	47	48	49	50	51	52	53	54	55	56	57
Id. No.	203069	203070	203071	203072	203073	203074	203075	203076	203077	203078	203079	203080	203081
Ø	58	59	60	61	62	63	64	65	66	67	68	69	70
Id. No.	203082	203083	203084	203085	203086	203087	203088	203089	203090	203091	203092	203093	203094
Ø	71	72	73	74	75	76	77	78	79	80			
Id. No.	203095	203096	203097	203098	203099	203100	203101	203102	203103	203104			

EM-S-4**

Ø	70	71	72	73	74	75	76	77	78	79	80	81	82
Id. No.	203434	203435	203436	203437	203438	203439	203440	203441	203442	203443	203444	203445	203446
Ø	83	84	85	86	87	88	89	90	91	92	93	94	95
Id. No.	203447	203448	203449	203450	203451	203452	203453	203454	203455	203456	203457	203458	203459
Ø	96	97	98	99	100	101	102	103	104	105			
Id. No.	203460	203461	203462	203463	203464	203465	203466	203467	203468	203469			

* The clamping sleeves have a max. radial expansibility in diameter of ± 0.4 mm from the nominal diameter.

** The clamping sleeves have a max. radial expansibility in diameter of ± 0.6 mm from the nominal diameter.

Soft work stop blank

Type	EM-S-1	EM-S-2	EM-S-3	EM-S-4
Id. No.	203106	203107	203108	203433
A	93	105	113	142
C	47	59	75	82.5
D	80	95	88	115
E	12.5	22	27	30
F	27.5	30.5	40.5	45
H	6	6	-	-
I	50	70	88	116
K	82	100	114	143
M	19	31	46	71
N	66	82	100	128
O	M5	M5	M5	M5

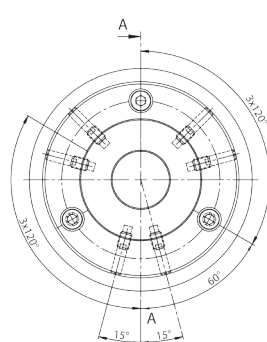

EM-S-1

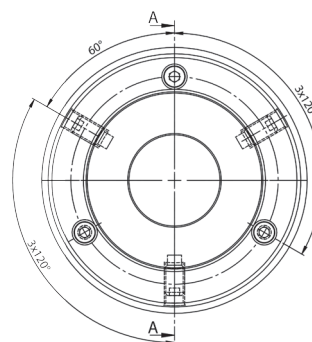

EM-S-2 / EM-S-3 / EM-S-4

